

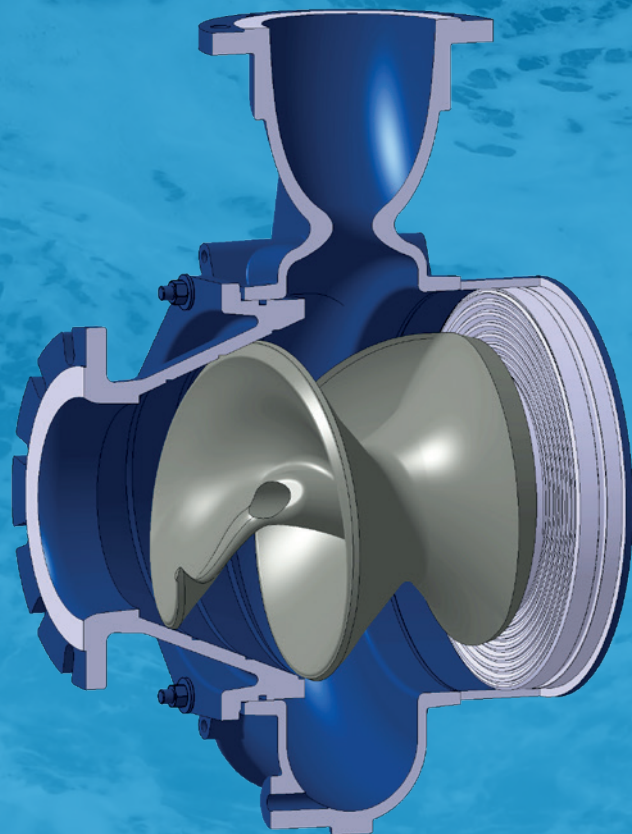

EN

Hydraulics

The Hidrostal hydraulic system reliably and efficiently solves pumping problems in all application areas. For more than 60 years, Hidrostal pumps with their original screw impeller have been pumping wastewater, liquids with a high solid content, foodstuffs, slurry and sludge, fibrous materials, abrasive and gaseous media and much more.



Optimal conveyance and low operating costs

Hidrostal pumps ensure virtually clog-free and reliable operation even under the most demanding conditions. The pumps are characterised by their diverse application possibilities: Conveying sludge and wastewater, pumping water out of excavation pits, private household uses, gentle food transport and many more applications.

Hidrostal hydraulic systems operate according to the centrifugal pump principle. The classic field of application of multi-blade centrifugal pumps is the conveyance of water or pure liquids of low viscosity. Multi-blade impellers have limited suction capacity and are not normally suitable for conveying liquids with solids.

The Hidrostal single screw centrifugal impeller can easily overcome this limitation. The suction area upstream of the impeller, and the design of the blade's inlet edge, enable extremely low required suction pressures (NPSH). This means, for example, that high flow rates of the pumped medium can be achieved at high pump speeds or extremely high temperatures. The efficiency of Hidrostal pumps is significantly higher than that of competing products used for similar applications. The pump head curves are continuous and steep and therefore enable the most cost-efficient adaptation of pump operation to the individual pumping requirement, in particular in speed-controlled operation.

Hidrostal is continually working on improving its products by using state-of-the-art methods such as CFD simulations and extensive prototype testing series.

By adapting the material alloys to the medium, application-specific impeller geometries have been developed. However, Hidrostal pumps also offer a high level of component and product standardisation. This ensures a long service life at the lowest possible cost. In addition, all Hidrostal products are available in different materials.

When pumping abrasive media, for example, a wear-resistant adjustable entry cone can be used. To pass corrosive media, all liquid-carrying components can be manufactured in stainless steel. Hidrostal special alloys are used for extremely corrosive and abrasive media.

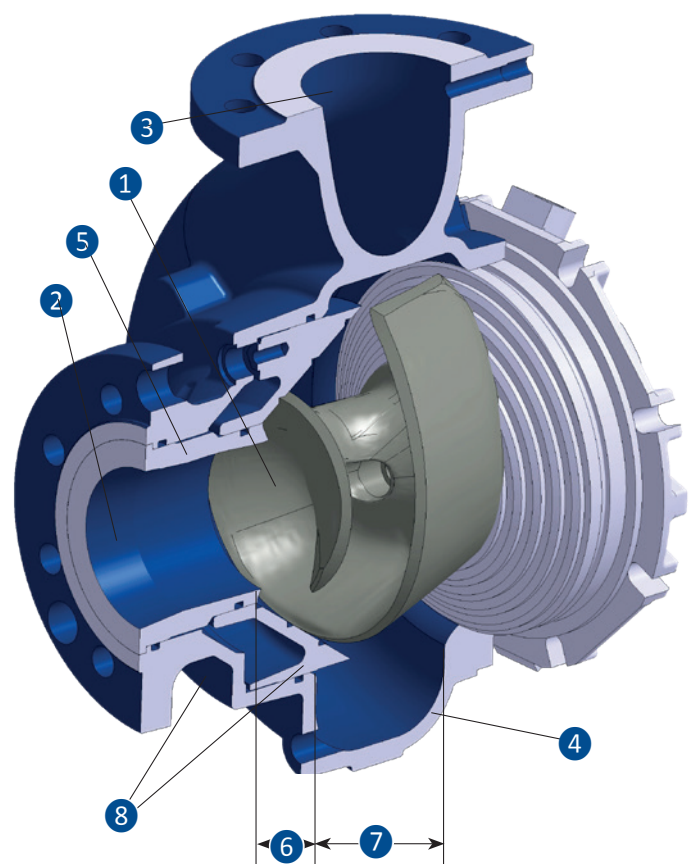



Pump design

- ① Screw impeller
- ② Inlet
- ③ Outlet
- ④ Volute casing
- ⑤ Suction cone
- ⑥ Screw impeller section
- ⑦ Centrifugal impeller section
- ⑧ Adjustment of clearance

Every pumping task requires specific pump characteristics.

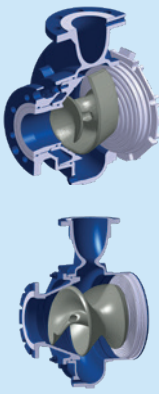
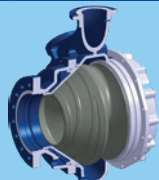
Hidrostal can offer the optimal product from a range of 500 standard versions available. In addition, Hidrostal has developed customised solutions and entire pump series in close co-ordination and cooperation with its customers.

Impeller type	Application	Example
Open Q- & K-line 	Conveying granulates	Suspended cereal, crystals, flakes
	Coarse, suspended solids	Solids-containing media, unscreened wastewater and slaughterhouse waste
	Fibrous materials with a tendency to become entangled	Suspended textiles and synthetic fibres such as nylon and wet wipes
	Solids with abrasive character	Surface water containing dirt and sand
	Viscous, muddy and gaseous liquids	Paint, glue, paper pulp, sludge from sedimentation, as well as gas-generating or flake-forming biological processes
Sealed V-line 	Highly abrasive media	Liquids with large quantities of sand or chippings as well as grinding and macerated waste
Sealed F-line 	Gentle conveying of voluminous materials	Sensitive materials such as fruit, vegetables and live fish

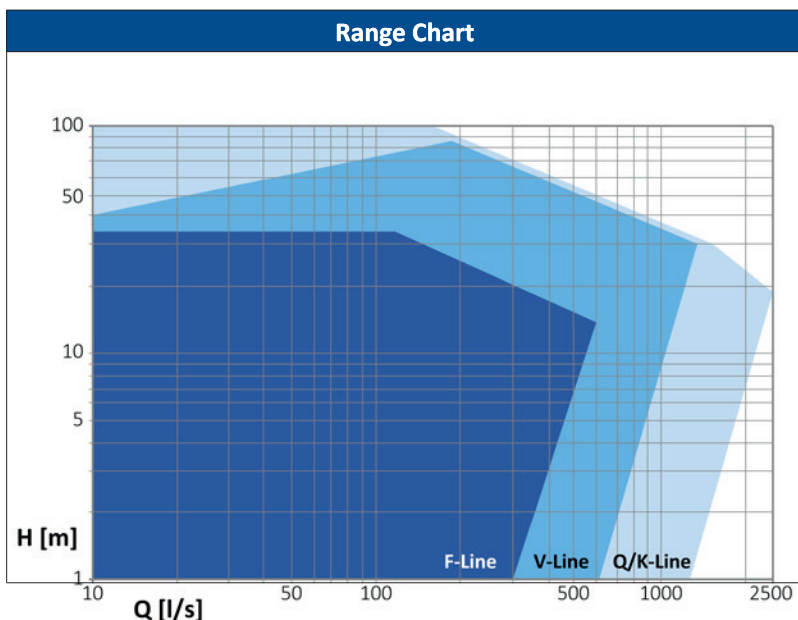

- Optimal operating point selection through more than 500 hydraulic variations
- Multiple versions
- High efficiencies
- Excellent absorbency

Hidrostal Pumps

Make a quick and accurate pump selection:
www.hidrostal.com/pumpselector.php



Due to their outstanding characteristics, Hidrostal pumps are used in numerous municipal and industrial sectors all around the world. Our pumps are custom-made and are specially tailored to the needs of each location. Our specialists select the suitable material combinations and individually adapt every pump to the local conditions. We ensure with this process that Hidrostal pumps are successful in difficult applications and achieve the best results with respect to performance, energy efficiency and low life-cycle costs.

- clog-free pumping
- high suction capacity
- gentle delivery due to low shear forces
- high efficiency
- stable, steep pump curve
- long service life
- low pulsation
- continuous flow proportional to the speed
- high pressure stability across a wide speed range



info@hidrostal.com
www.hidrostal.com

