

CDSW

Self Priming Centrifugal Pump

Basic Pump

Model V6A60-B

Size 8" x 6"



PUMP SPECIFICATIONS

- Size:** 8" x 6" (203 mm x 154 mm).*
- Pump Casing:** Gray Iron No. 30.†
- Maximum Operating Pressure 129 psi (889 kPa).**
- Semi-Open Type, Two Vane Impeller:** Ductile Iron No. 65-45-12.
Handles 3" (76,2 mm) Diameter Spherical Solids.
- Impeller Shaft:** Alloy Steel No. 4140.
- Self-Cleaning Replaceable Wear Plate:** Carbon Steel No. 1015.†
- Shimless Adjustable Cover Plate:** Gray Iron No. 30.†
- Externally Removable Flap Valve:** Neoprene w/Nylon and Steel Reinforcing.
- Flap Valve Seat:** Gray Iron No. 30.
- Bearing Housing:** Gray Iron No. 30.
- Seal Plate:** Gray Iron No. 30.
- Shaft Sleeve:** Alloy Steel No. 4130.
- Radial and Thrust Bearings:** Open Double Ball.
- Bearing and Seal Cavity Lubrication:** SAE No. 30 Non-Detergent Oil.
- Gaskets:** Buna-N, Compressed Synthetic Fibers, Vegetable Fiber, PTFE, Cork, and Rubber.
- O-Rings:** Buna-N.
- Hardware:** Standard Plated Steel.
- Brass Pressure Relief Valve.**
- Bearing and Seal Cavity Oil Level Sight Gauges.**
- Optional Equipment:** Automatic Air Release Valve. High Pump Temperature Shutdown Kit. Stainless Steel/G-R Hard Iron Impeller and Wear Plate. 120/240 Volt Casing Heater.



*Optional Gray Iron No. 30 Suction/Discharge Flanges Available as Follows (See Price Sheets):
 8" and 6" 125# Female NPT Kit.
 8" and 6" ASA Spool Kit.
 200 mm and 150 mm DIN 2527 (PN 16) Spool Kit.

† **Gorman-Rupp Patented/Patent Pending Feature.**

SEAL SPECIFICATIONS

Cartridge Type, Mechanical, Oil-Lubricated, Double Floating, Self-Aligning. Silicon Carbide Rotating and Stationary Faces. Stainless Steel No. 316 Stationary Seat. Fluorocarbon Elastomers (DuPont Viton® or Equivalent). Stainless Steel No. 18-8 Cage and Spring. Maximum Temperature of Liquid Pumped, 160°F (71°C).†††

****Consult Factory for Applications Exceeding Maximum Pressure and/or Temperature Indicated.**

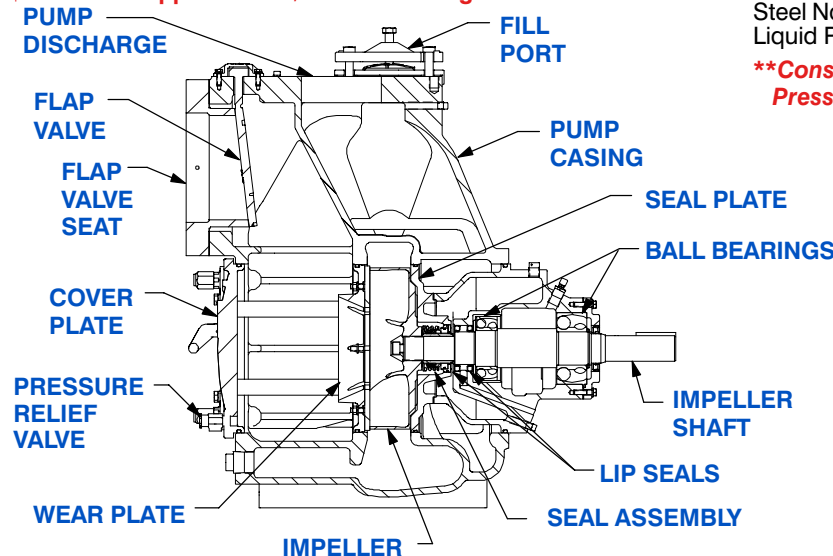

SEAL DETAIL

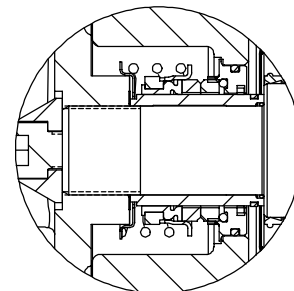

THE GORMAN-RUPP COMPANY • MANSFIELD, OHIO

GORMAN-RUPP OF CANADA LIMITED • ST. THOMAS, ONTARIO, CANADA

www.gormanrupp.com

Specifications Subject to Change Without Notice

Printed in U.S.A.

Specification Data

NET WEIGHT: 1130 LBS. (512 KG.)*
SHIPPING WEIGHT: 1180 LBS. (535 KG.)*
EXPORT CRATE: 25 CU. FT. (0,71 CU. M.)
 *WEIGHTS DO NOT INCLUDE OPTIONAL FLANGE KITS.

SECTION 55, PAGE 2700

APPROXIMATE DIMENSIONS and WEIGHTS

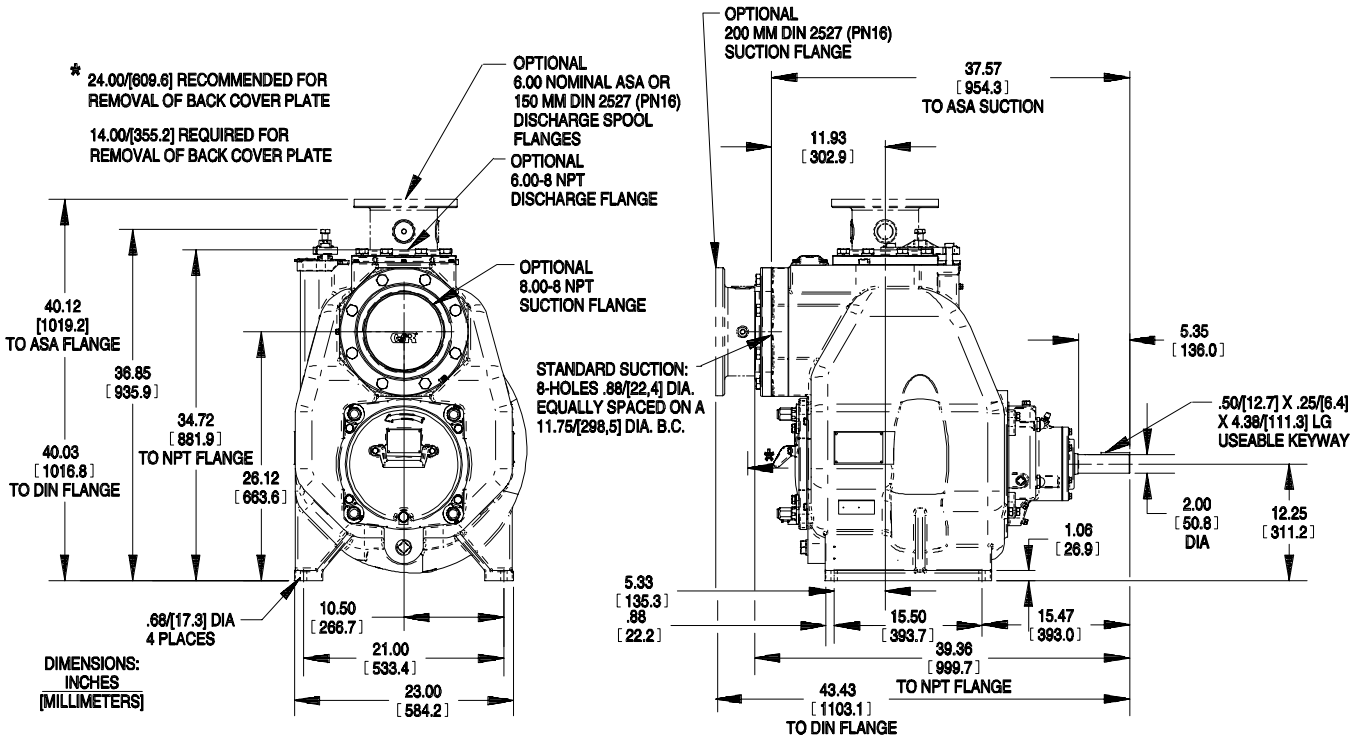

OPTIONAL SUCTION & DISCHARGE FLANGES SHOWN IN PHANTOM

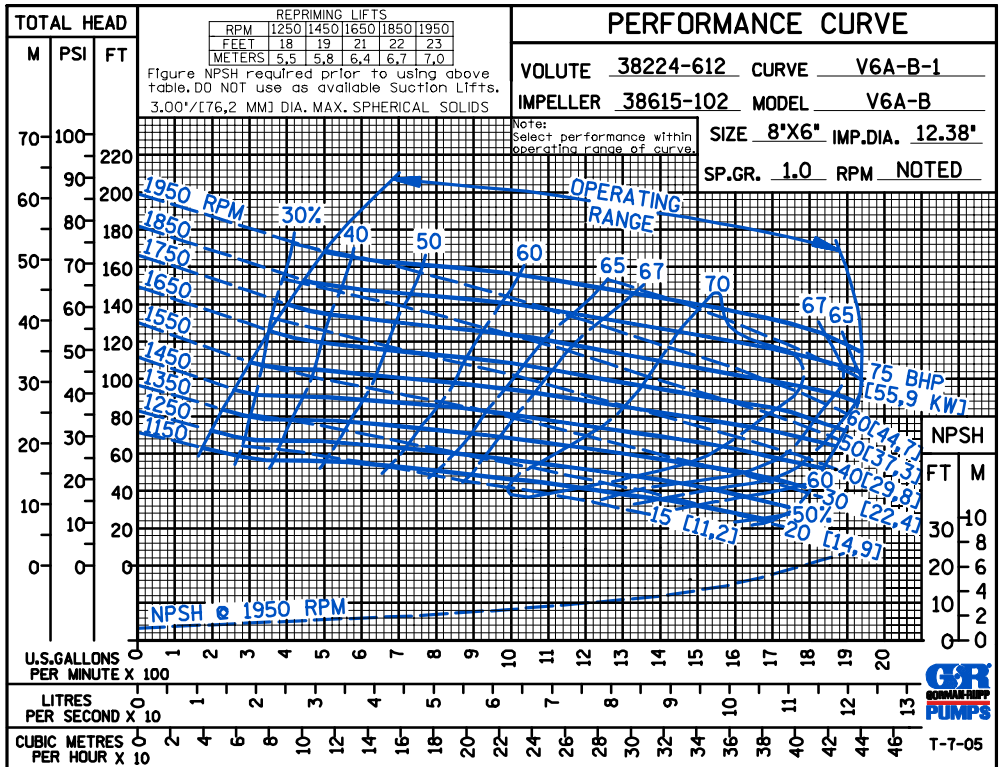

THE GORMAN-RUPP COMPANY • MANSFIELD, OHIO

GORMAN-RUPP OF CANADA LIMITED • ST. THOMAS, ONTARIO, CANADA

Specifications Subject to Change Without Notice

Printed in U.S.A.