



UC SERIES

MODEL UC4310H (A70 - 4X3X10)



UC4310H PERFORMANCE 1750 RPM, 60 Hz

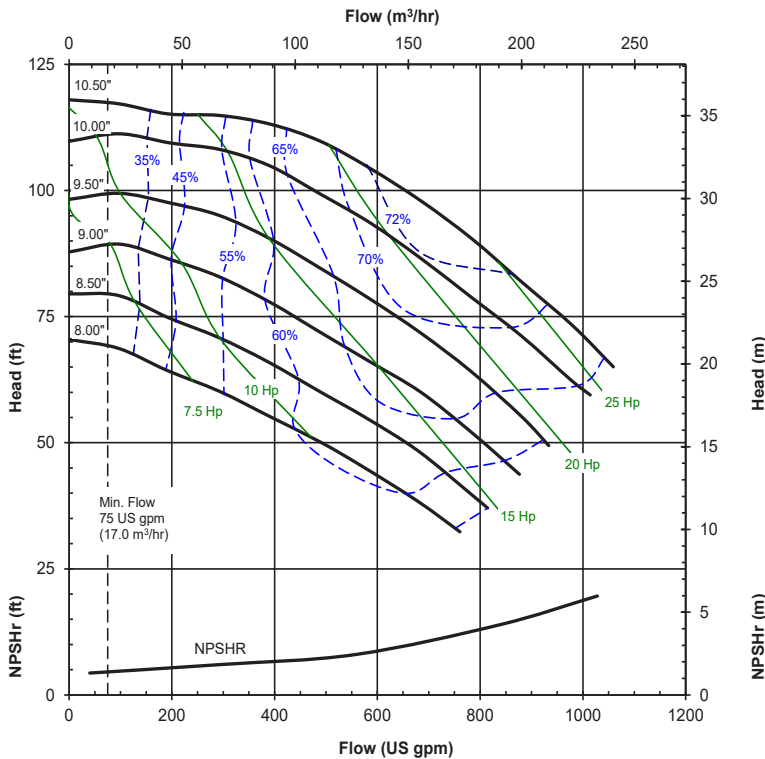

UC4310H PERFORMANCE 1450 RPM, 50 Hz

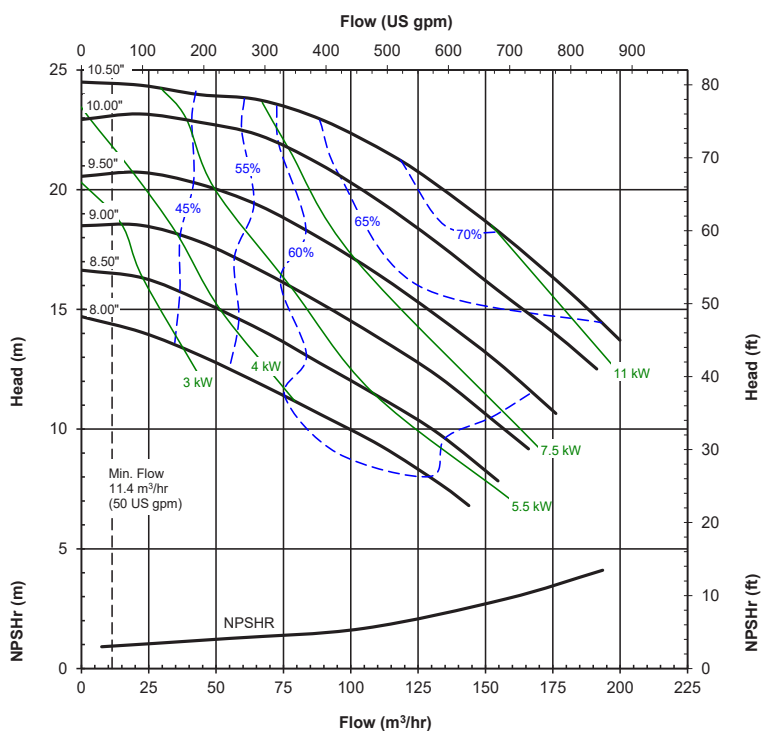

FEATURES

- Durable, corrosion-resistant Tefzel® lined ductile iron casing
- Casing meets ANSI B73.1m & 73.3 for foot and flange location
- Powerful neodymium magnets for dependable, leak-free operation
- Conventional volute
- Rear sealing ring to balance axial thrust
- Dual bushings provide optimum alignment
- Suction shaft support with integral straightening vanes
- Replaceable 2-piece impeller and drive hub
- Run dry capability with carbon or Dri-Coat SiC bushing
- Easy-set measurement free outer drive
- Exclusive vapor protection package to protect outer magnetic drive and motor face from corrosive fumes
- Back pull-out design
- Casing drain standard
- Specific gravity over 1.8
- Accepts standard NEMA 143-405 or IEC 90-280 motor frames
- ANSI or ISO flange mountable
- ATEX certified models available



TYPICAL APPLICATIONS

- Paper Mills
- Water treatment
- Plating & metal finishing
- Chemical manufacturing, blending, distribution
- Fume scrubbers
- Pharmaceuticals
- Truck loading/unloading
- Metals manufacturing
- Electronics

TYPICAL CHEMICALS

- Sodium hydroxide
- Sulfuric acid
- Hydrochloric acid
- Sodium hypochlorite
- Plating solutions
- Corrosive blends
- Solvents
- Wastewater

*Tefzel® Fluoropolymer Resin is a registered trademark of DuPont

UC SERIES

Item No.	Description	Construction
1	Casing	Cast ductile iron, DuPont Tefzel® (ETFE) lined
2	Shaft support	Carbon fiber filled ETFE
2A	Front thrust ring	Alpha sintered silicon carbide
3	Impeller	Carbon fiber filled ETFE
3A	Impeller thrust washer	Alpha sintered silicon carbide
4	Inner drive	Neodymium iron boron magnets encapsulated in ETFE
4A	Bushing	Alpha sintered silicon carbide, Dri-Coat silicon carbide, or carbon
4C	Rear sealing ring	GF molybdenum disulfide-filled PTFE
5	Shaft	Alpha sintered silicon carbide
6	Barrier	Molded CF ETFE liner with Aramid Reinforced Epoxy external shell
6A	Barrier thrust ring	Alpha sintered silicon carbide
7	Clamp ring	Painted ductile iron
8	Outer drive magnet	Nickel-plated neodymium iron boron magnets/painted ductile iron
9	Motor adapter	Ductile iron
10	O-ring	FKM, EPDM, FEP/FKM, Kalrez®, Simriz®, or Afias®
11	Vapor protection o-rings	Buna

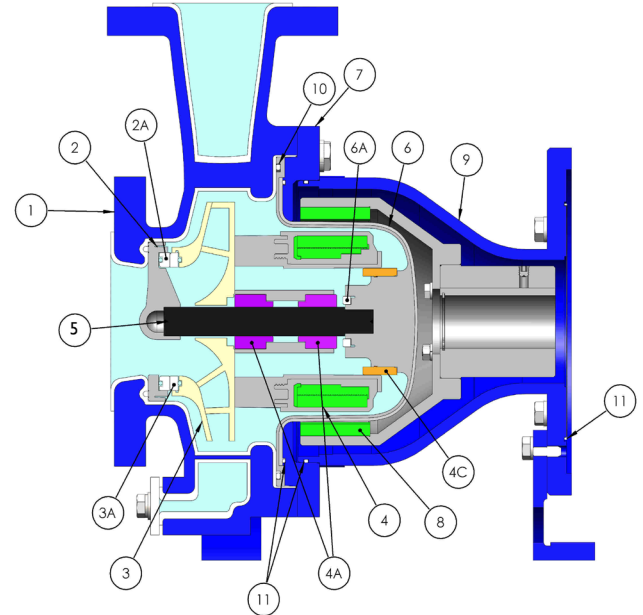

Kalrez® is a registered trademark of DuPont Performance Elastomers
 Simriz® Perfluoroelastomer is a registered trademark of Simrit® division of Freudenberg-NOK.
 Afias® is a trademark of the Asahi Glass Co., Ltd.

SPECIFICATIONS

HP (kW)	Impeller Diameter	Suction	Discharge	Max. Flow 1750 rpm		Max. Head 1750 rpm		Max. Working Pressure psi (Bar)	Max. Viscosity cP	Max. Specific Gravity	Max. Temp.* °F (°C)
	in (cm)	in (cm)	in (cm)	gpm	m ³ /hr	ft.	m				
1 - 50 (1.1- 37)	8 - 10 1/2 (20.3 - 27)	4 (10.2)	3 (7.6)	1050	239	118	36	300 (20.7)	200	1.8	250 (121)

*Except E magnet set: maximum 220° F (104° C)
 Note: Impeller trims available every 1/8" (.32 cm) between the smallest and largest diameters.

DIMENSIONS

FRONT VIEW

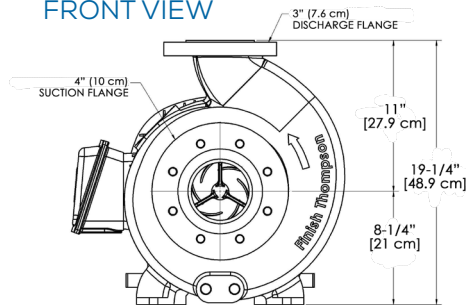

SIDE VIEW

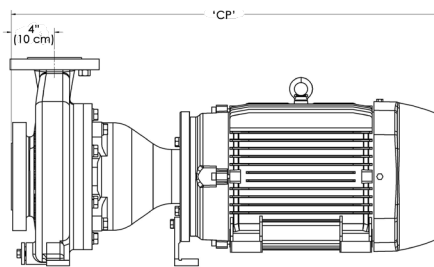

BOTTOM VIEW

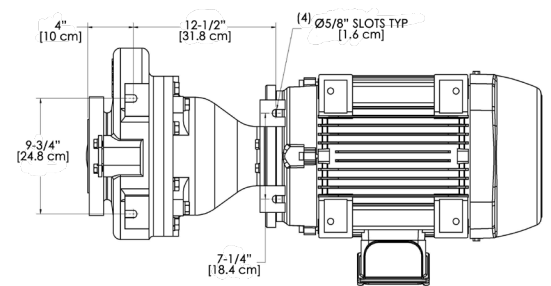

ANSI 150#, 300#, & ISO/
 DIN PN40 flanges are in
 compliance with bolting
 dimensions only.

NEMA Motor Frames	CP (approx.)	
	in	cm
143-145TC	27-11/16	70.3
182/184TC	29-9/16	75.1
213/215TC	32-5/8	82.9
254/256TC	37-1/2	95.3
282/284TC/TSC	39-27/32	101.2
324/326TC/TSC	44-21/32	113.4
364/365TC/TSC	46-27/32	119.0
404/405TSC	50-5/16	127.8

IEC Motor Frames	CP (approx.)	
	in	cm
90	27-15/32	69.8
100/112	28-29/32	73.4
132	32-9/16	82.7
160	38-9/32	97.2
180	40-9/16	103
200	43-3/32	109.5
225	46-21/32	118.5
250	52-17/32	133.4
280	56-3/4	144.1



finishthompson.com

FINISH THOMPSON INC. - UNITED STATES

921 Greengarden Road | Erie, PA 16501
 800.934.9384 | ph 814.455.4478 | fx 814.455.8518
 email fti@finishthompson.com

FINISH THOMPSON INC. - GERMANY

Otto-Hahn-Strasse 16 | Maintal, D-63477 Germany
 49 (0)6181-90878-0 | fx 49 (0)6181-90878-18
 email fti@finishthompson.com