

E3 DATA SHEET

SPECIFICATIONS & PERFORMANCE

3" Metal Food Processing - ATEX

with Metal Center Section

PERFORMANCE

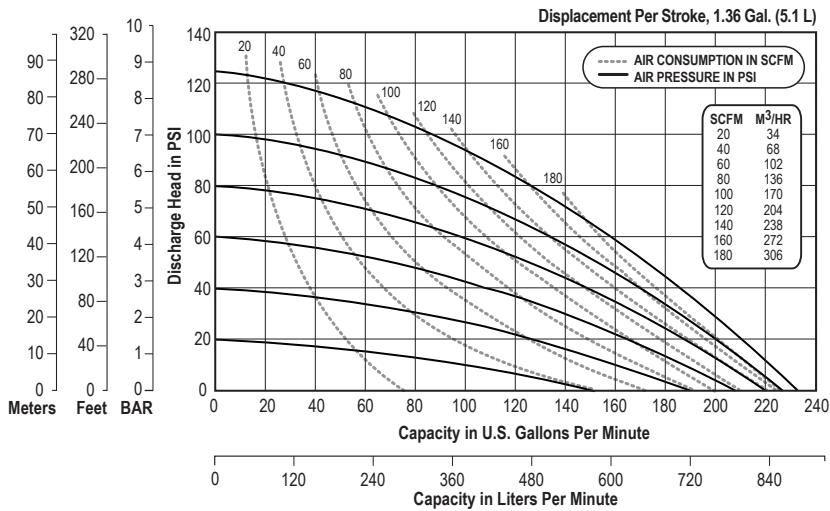

NOTE: Performance based on the following: elastomeric fitted pump, flooded suction, water at ambient conditions. The use of other materials and varying hydraulic conditions may result in deviations in excess of 5%.

SPECIFICATIONS

Flow Rate

Adjustable to . . .0-234 gpm (886 lpm)

Port Size

Suction3" TRI-CLAMP

Discharge3" TRI-CLAMP

Air Inlet 1/2" NPT

Air Exhaust1" NPT

Suction Lift

Dry20' (6.1 m)

Wet32' (9.8 m)

Max Solid Size (Diameter)

.3/8" (9.5 mm)

Max Noise Level 96 dB(A)

Shipping Weights

Stainless 189 lbs (86 kg)

** Stainless Center add50 lbs. (22.7 kg)

DIMENSIONS

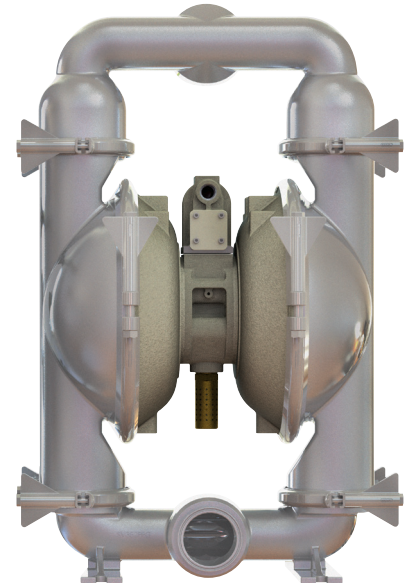
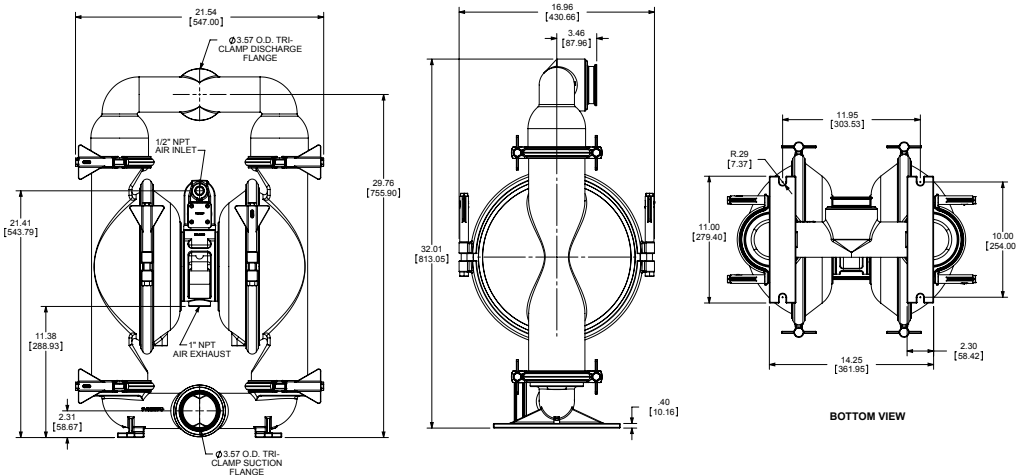

Warren Rupp, Inc. | A Unit of IDEX Corporation
 800 North Main Street | Mansfield, OH 44902 USA
 Phone: 419.526.7296 | Fax: 419.526.7289

VERSAMATIC.COM

e3mdlCdsATEXFP-rev0519

©Copyright 2019 Warren Rupp, Inc. All Rights Reserved.